



- MODELS
- VB-42-B
  - VB-42-B-LP
  - VB-60-B
  - VB-60-B-LP
  - VB-60-T
  - VB-60-H
  - VB-60-X
  - VB-60-H-DC
  - VB-60-H-LP
  - VB-72-B
  - VB-72-B-LP
  - VB-72-T
  - VB-72-H
  - VB-72-X
  - VB-72-H-DC
  - VB-72-H-LP



“Equipping The World For A Better Environment”



# Congratulations

You have just purchased a quality designed and manufactured CRAM-A-LOT® Baler. Manufacturing balers and compactors since 1978, J.V. Manufacturing offers quality workmanship, factory trained installation and a national service network. Advanced features have been designed into the Baler for modern waste disposal operations.

As with any investment, a return is expected, and the return received from this investment will be in the form of maximum performance during many years of dependable service.

In order to maintain quality performance and safe operation of your new baler, it is necessary to observe and practice the operation and maintenance information provided in this manual.

The employer involved in the operation, maintenance, and installation of the baler should read and understand the most current version of the following applicable standards.

ANSI Standard No. Z245.5, "Baler-Safety Requirements for Installation, Maintenance and Operation".

A copy of this standard may be obtained from:  
ENVIRONMENTAL INDUSTRIES ASSOCIATION  
4301 Connecticut Avenue, NW  
Washington D.C. 20008  
Website <http://www.wastec.org>

If, after thoroughly reading this manual, there are questions about the operation or repair of your baler, please contact J.V. Manufacturing, Inc., and our Customer Support Team will provide assistance.

## **CRAM-A-LOT® Customer Support**

**Tel: 800-754-4290**

**Fax: 479-751-7870**

**Hours: 7:00 am - 5:00 pm CST®**

**Monday - Friday**  
**[Service@jv.com](mailto:Service@jv.com)**

## **JV Manufacturing Corporate Philosophy**

It is the stated goals of J.V. Manufacturing, Inc. to build equipment of uncompromising quality, provide the absolute best customer service in our industry, and to conduct all business with honesty and integrity, whether it be with customers, vendors, fellow employees or members of the community.

J.V. Manufacturing, Inc. encourages positive change. Change will provide opportunities for future growth and new directions as we move into the future.



# Table of Contents

Manual0025 Rev. K. Effective 04-07-16

<b>Introduction</b>	<b>5</b>
<b>Installation Guidelines</b>	<b>6-7</b>
Positioning.....	6
Anchoring.....	7
Electrical.....	7
Hydraulic.....	7
<b>Baler Operation</b>	<b>8-13</b>
Responsibilities of the Owner / Operator.....	8
Safety Orientation.....	9
Controls.....	10
Emergency Operation.....	11
Baler Operation.....	11
Making & Tying a Bale.....	11
Making & Tying a Bale with Front Feed Wire Guide Option.....	12
Ejecting a Bale.....	12
Bale Tie Configuration.....	13
<b>Maintenance</b>	<b>14-18</b>
Lockout & Tagout Procedures.....	14
Chocking the Presshead.....	15
Preventive Maintenance Schedule.....	16
Decal Locations & Ordering Information.....	17
Checking and Adding Oil.....	18
<b>Troubleshooting</b>	<b>19-20</b>
<b>Technical Specifications</b>	<b>21-22</b>
<b>Parts Diagrams</b>	<b>23-27</b>
Chassis , Loading Door.....	23-24
Power Unit .....	25
Hydraulic Tank .....	26
Control Panel .....	27
<b>Schematics</b>	<b>28-29</b>
Electrical Schematic.....	28
Hydraulic Schematics.....	29
<b>Warranty Policy &amp; Procedures</b>	<b>30-32</b>

# Installation Guidelines

## REQUIRED FLOOR SPACE

Your **CRAM-A-LOT**<sup>®</sup> Vertical Baler requires up to 132 square feet of clear floor space for proper installation and operation. (11' x 12') This space should always be kept clear of materials which could interfere with the safe operation of the baler. **WARNING:** Foreign objects can fall into the bale chamber between the rear supports of the baler, wedge under the presshead and turn the baler over onto its front. Damage to the baler and personal injury can result. **ALWAYS** keep this area clean.

## POSITIONING

Position the vertical baler indoors or under a suitable cover so that sufficient room is available for proper and safe operation. The baler should be placed no less than 24 inches from any structure to allow room to insert wires and tie off the bale. The power unit side of the baler should be placed no less than 36 inches from any structure to allow room to open the chamber door and access the back of the unit. Adequate room must also be present in front of the baler to allow the chamber door to swing fully open so the finished and tied bale can be ejected.

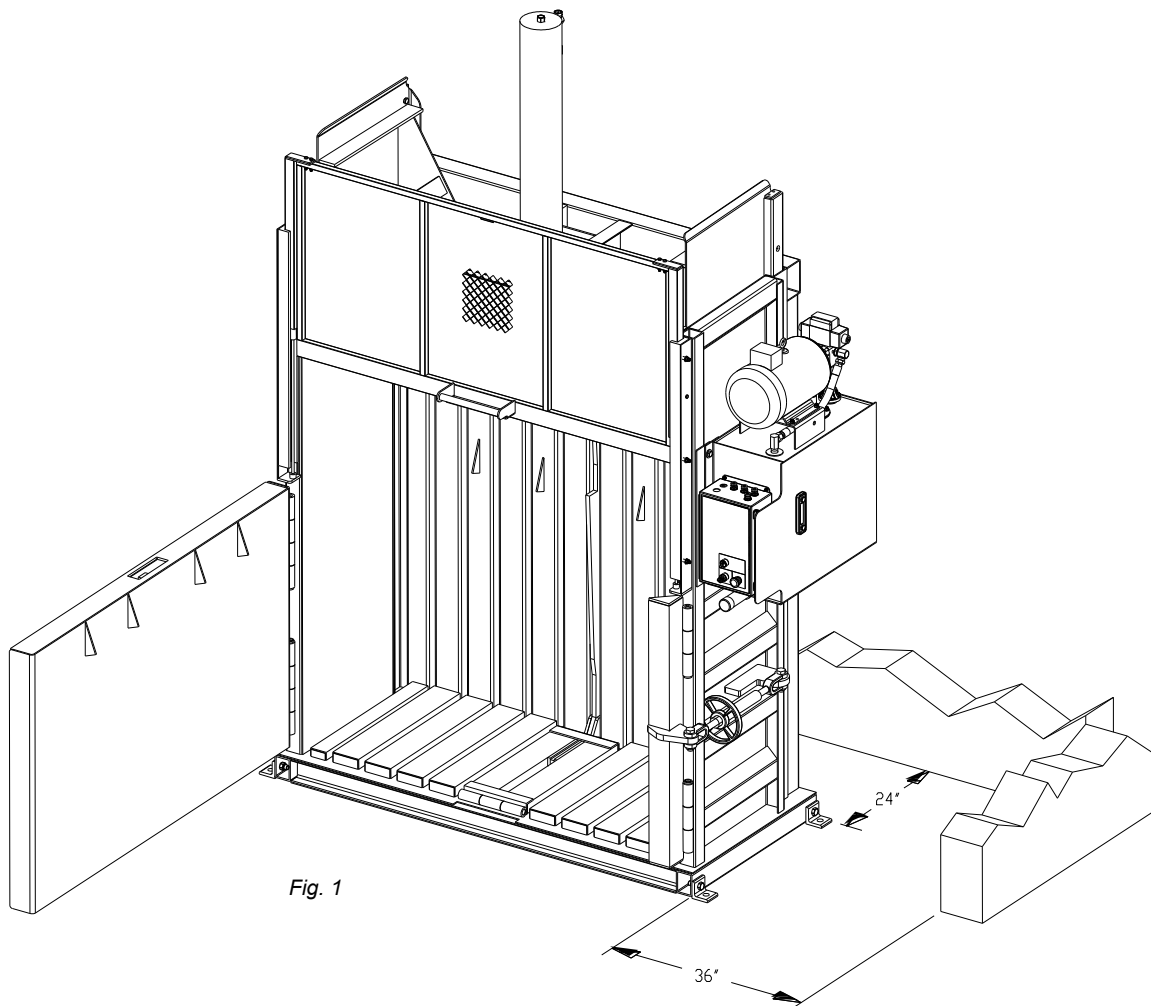

# ***Installation Guidelines, cont.***

## ***ANCHORING***

The recommended mounting surface for the baler is a pad of steel reinforced concrete with a minimum 3,000 psi capacity. The pad should be at least 4 inches deep. The baler should be anchored using the anchor pads provided with the machine. The anchor pads should be fastened to the baler footer using the supplied hardware. Secure the anchor pads to the mounting surface with 4 anchor bolts (minimum 3/8"x4"). To allow for construction variances, the holes should be drilled after locating the baler in the desired position.

## ***ELECTRICAL***

A lockable fused disconnect switch (customer furnished) must be installed within 50 feet, and in line of sight of the baler electrical enclosure. This disconnect must be sized in accordance with the baler motor and voltage.

## ***GROUNDING INSTRUCTIONS***

This appliance must be connected to a grounded, metal, permanent wiring system; or an equipment-grounding conductor must be run with the circuit conductors and connected to the equipment-grounding terminal or lead on the appliance. A qualified electrician should be consulted if there is any doubt as to whether an outlet box is properly grounded.

## ***HYDRAULIC***

Install the included vented cap on the hydraulic tank before operating the machine.

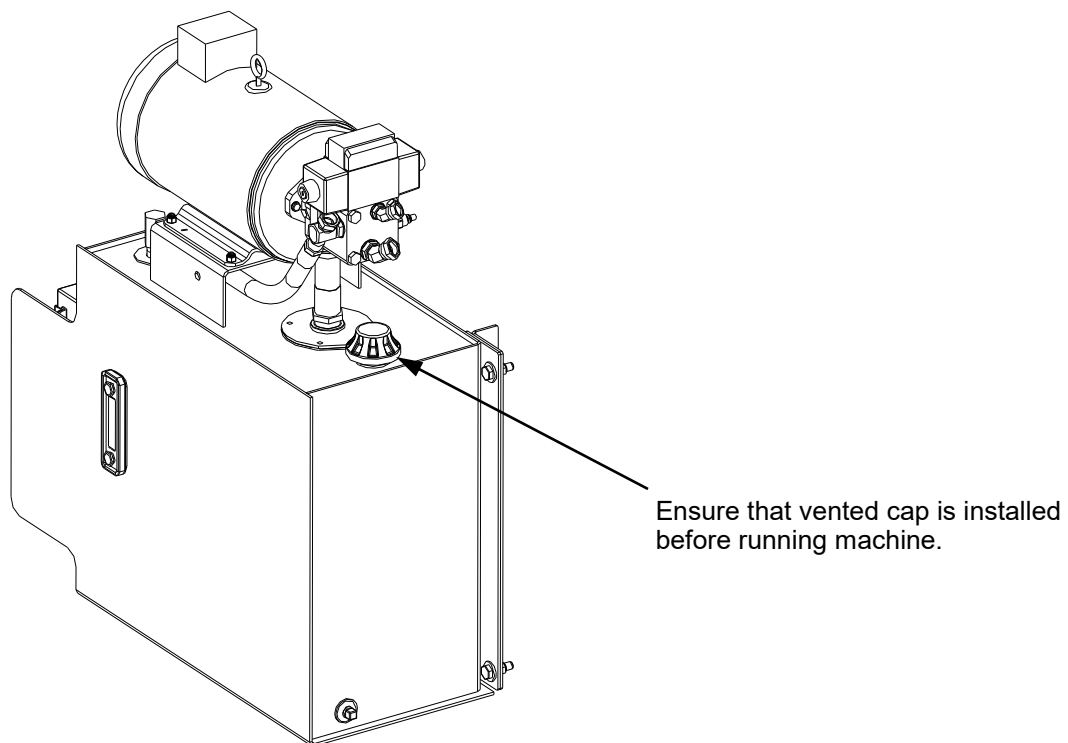

Fig. 2

# ***Baler Operation***

## ***ANSI Guidelines***

### ***Responsibilities of the Owner / Employer***

The employer / owner shall ensure that the vertical baler is properly maintained and meets all applicable regulatory standards and shall be responsible for the following:

1. Ensuring that the installation of the equipment conforms with all local codes, ordinances, and manufacturer's recommendations.
2. Providing instruction and training to employees on safe work methods, including procedures provided by the manufacturer, before assigning them to operate, clean, service, maintain, modify, or repair the equipment. The owner / employer will maintain records as to the names of employees and the dates of training.
3. Monitoring the user's / employee's operation of the baler and taking appropriate action to ensure proper use of the equipment including adherence to safe practices.
4. Repairing any mechanical malfunctions or breakdowns that affect the safe operation of the baler.
5. Establishing and following a program of periodic and regular inspections of the equipment to ensure that all parts, component equipment, and safeguards are in safe operating condition, and adjusted, in accordance with the manufacturer's recommended procedures. This shall include keeping all malfunction reports and record inspections and maintenance work performed.
6. Using the manufacturer's recommended procedures for the lockout/tagout of hazardous energy sources. (See OSHA 29 CFR 1910.147, Appendix A, for recommended lockout/tagout procedures.)
7. Providing for an adequate work area around the equipment for safe maintenance, servicing, and cleaning procedures (see OSHA 29 CFR 1910.303 for electrical equipment).
8. Keeping all surrounding walking areas and floors free from obstructions, and accumulations of waste matter, grease, oil, and water.
9. Maintaining records or employee reports of malfunctions.
10. Specifically inspecting safety interlocks, switches, and other protective devices to ensure that these devices are not disabled or bypassed, and not to permit the equipment to be operated unless these devices are fully functional. These inspections shall be in accordance with item 5.
11. Ensuring that only authorized employees (18 years old or older) operate, inspect, or maintain the equipment.

### ***Responsibilities of the Operator / Employee***

The operators / employees who work on and around the vertical baler shall be responsible for the items listed below:

1. Using all applicable safety features provided on the equipment.
2. Using the equipment only after receiving instruction.
3. Reporting any damage to, or malfunction of, the equipment by submitting a report to the employer or responsible authority when the damage or malfunction occurs.
4. Ensuring that all access doors and service opening covers are in place, secure, and/or locked before operations begin.
5. Ensuring that the area of operation around the baler is clear of all persons during all phases of the dumping operation prior to energizing the dumping system.
6. Ensuring that all persons are clear of the equipment point of operation before actuating any compaction cycle controls or dumping controls and shall be ready to stop the compaction cycle or dumping operation if necessary.
7. Ensuring that all persons are clear of the chamber door before the chamber door is opened or closed. The operator shall warn all persons not to cross behind or under and open chamber door.
8. Using the equipment in accordance the manufacturer's instructions, including ensuring the proper position of all locks, doors, guards, etc.
9. Ensuring that no one disables or bypasses safety interlocks, switches, or other protective devices and that the equipment is not operated unless these devices are fully functional.
10. Locking out the unit when: inspecting malfunctions, jams, or other problems arising from daily operations; servicing; or performing maintenance (except maintenance testing). The affected employee shall identify the type and magnitude of energy that the equipment uses, shall understand the hazards, and know the methods to control the energy.
11. Operating, inspecting, and maintaining the equipment only if 18 years old or older and after being properly instructed and trained.

# ***Baler Operation, cont.***

## ***Safety Orientation***

### ***Safe Operation***

CRAM-A-LOT® balers meet or exceed all safety standards set by ANSI. Although we have included many safety features in the design and construction of your baler, safe operation of the equipment depends on the operator's adherence to certain guidelines. To prevent accidents to personnel or damage to the baler, the operator must **NEVER VIOLATE ANY OF THE FOLLOWING SAFETY PRECAUTIONS**. It is the owner / employer's responsibility to ensure these guidelines are known and followed by all operators of the baler.

NOTE: Publication of these safety precautions does not imply or represent an inclusive list.

**NEVER** place hands or arms in the baler while it is operating.

**NEVER** stand behind the baler while it is operating.

**NEVER** climb in or on the baler, nor perform any maintenance/repairs unless the power is disconnected and locked / tagged out.

**NEVER** allow anyone except qualified electrical or hydraulic repair persons to work on the equipment.

**NEVER** disable any safety switch.

**NEVER** overload the baling chamber.

**NEVER** place concrete, heavy steel plate or castings, explosive materials, liquids, nor hazardous waste in the baler.

NOTE: Hydraulic oil is the primary element of power transmission on the baler. Remember that hydraulic systems can remain pressurized even after the motor has stopped and or the power disconnected. Refer to the Lock Out / Tag Out instructions found elsewhere in this manual for instructions concerning the neutralization of these energy sources.

### ***Safety Terminology***

The accident prevention decals on your CRAM-A-LOT® baler meet or exceed standards set by ANSI and OSHA. It is important that you are familiar with the terminology used on the decals and the varying degrees of hazards that are associated with this terminology.

**DANGER**—Indicates an imminently hazardous situation which, if not avoided, will result in death or serious injury. This signal word is to be limited to the most extreme situations. The signal word Danger should not be used for property damage hazards unless personal injury risk appropriate to the level is also involved.

**WARNING**—Indicates a potentially hazardous situation which, if not avoided, could result in death or serious injury. This signal word should not be used for property damage hazards unless personal injury risk appropriate to this level is also involved.

**CAUTION**—Indicates a potentially hazardous situation which, if not avoided, may result in minor or moderate injury. It may also be used to alert against unsafe practices that may also cause property damage.

**NOTICE**—Indicates a statement of company policy directly or indirectly related to the safety of personnel or protection of property. This signal word should not be associated directly with a hazard or hazardous situation.

For information on proper decal location and ordering information, please see the Maintenance section of this manual.

# ***Baler Operation***

## ***Location of Baler Controls***

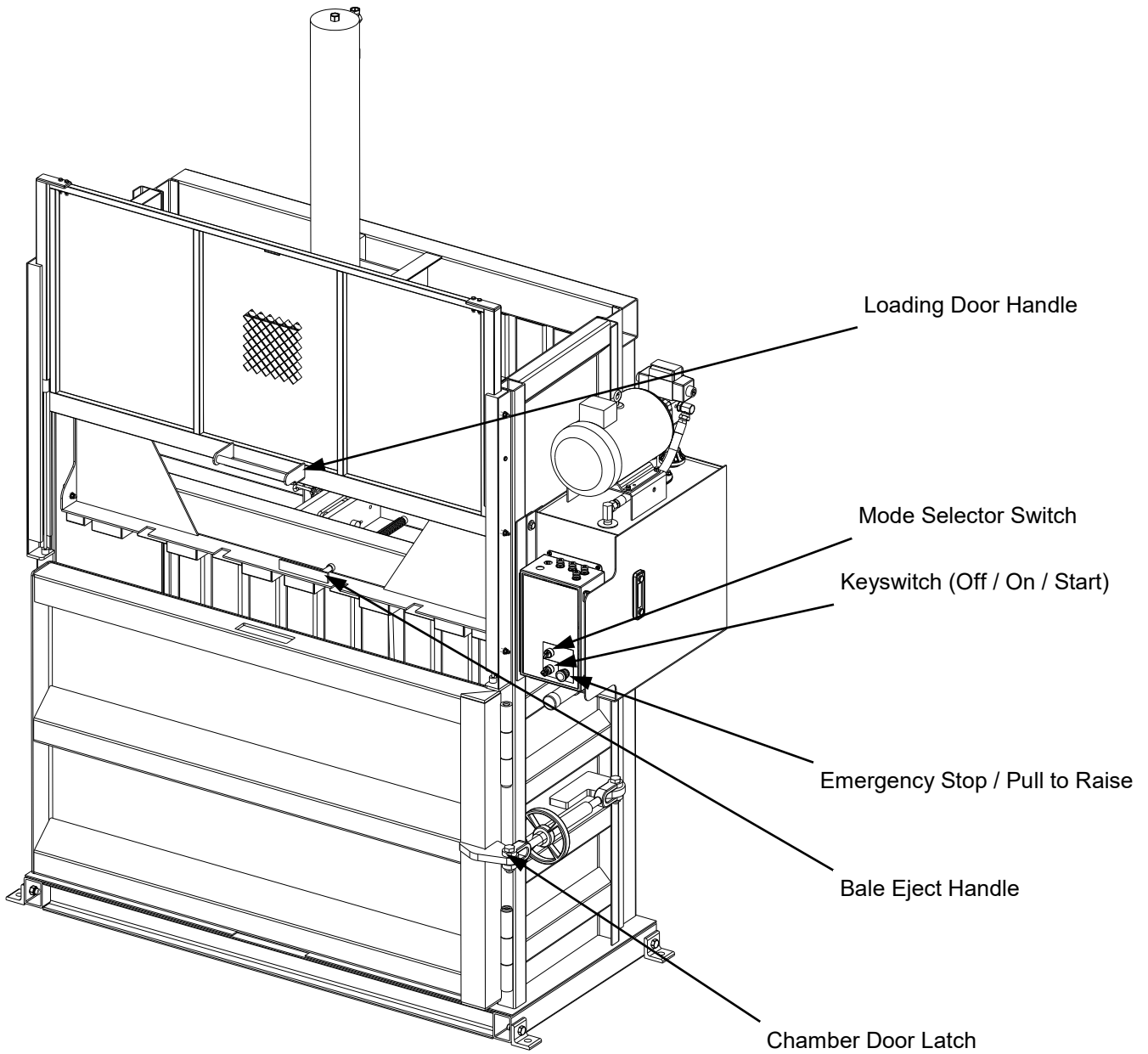

Fig. 3

# ***Baler Operation, cont.***



## **CAUTION**

It is unlawful to operate this machine if you are under 18 years of age!

### **Emergency Procedures**

Should an emergency occur while operating the baler, press the RED EMERGENCY STOP BUTTON and the baler will terminate all functions and shut down. **EVERYONE AUTHORIZED TO OPERATE THE BALER SHOULD KNOW THIS EMERGENCY PROCEDURE.**

### **Baler Operation**

#### ***Standard Baler Operation***

1. Open the chamber door by turning the turnbuckle on the chamber door latch. Position a full sheet of cardboard to cover the baler floor. Close and latch the chamber door.
2. Place material to be baled through the loading door into the baling chamber evenly until the chamber is full.
3. Close the loading door.
4. With the mode selector switch in "AUTO", insert the key into the start switch and turn to the "START" position until the presshead begins to descend.
5. Remove the key. At the end of the cycle, the baler will stop and the loading door will open.
6. Repeat steps 2 through 5 until the presshead shifts when the arrow on the baler aligns with the "100% Full" decal on the presshead.

#### ***Making and Tying a Bale***

1. Place a full sheet of cardboard to cover the top of the compacted material.
2. Close the loading door.
3. With the mode selector switch in "MANUAL DOWN", insert the key into the start switch and turn to the "START" position until the presshead begins to descend.
4. Remove the key. When the presshead descends and compresses the compacted material, the baler will stop and the loading door will open.
5.  CAUTION! Clear the area around the baler from all personnel and obstructions before proceeding!
6. Open the chamber door.
7. Insert the bale ties through the tie slots (see Figure 4) in the presshead and in the floor, pull snug and tie.

# Baler Operation, cont.

## Making and Tying a Bale with Front Feed Wire Guide option.

1. Place a full sheet of cardboard to cover the top of the compacted material.
2. Close the loading door.
3. With the mode selector switch in "MANUAL DOWN", insert the key into the start switch and turn to the "START" position until the presshead begins to descend.
4. Remove the key. When the presshead descends and compresses the compacted material, the baler will stop and the loading door will open.
5. CAUTION! Clear the area around the baler from all personnel and obstructions before proceeding!
6. Open the chamber door.
7. Insert the bale ties through the tie slots in the presshead first (see Figure 6) , feed wire through until it comes out of the slot in the floor, pull each wire snug and tie.

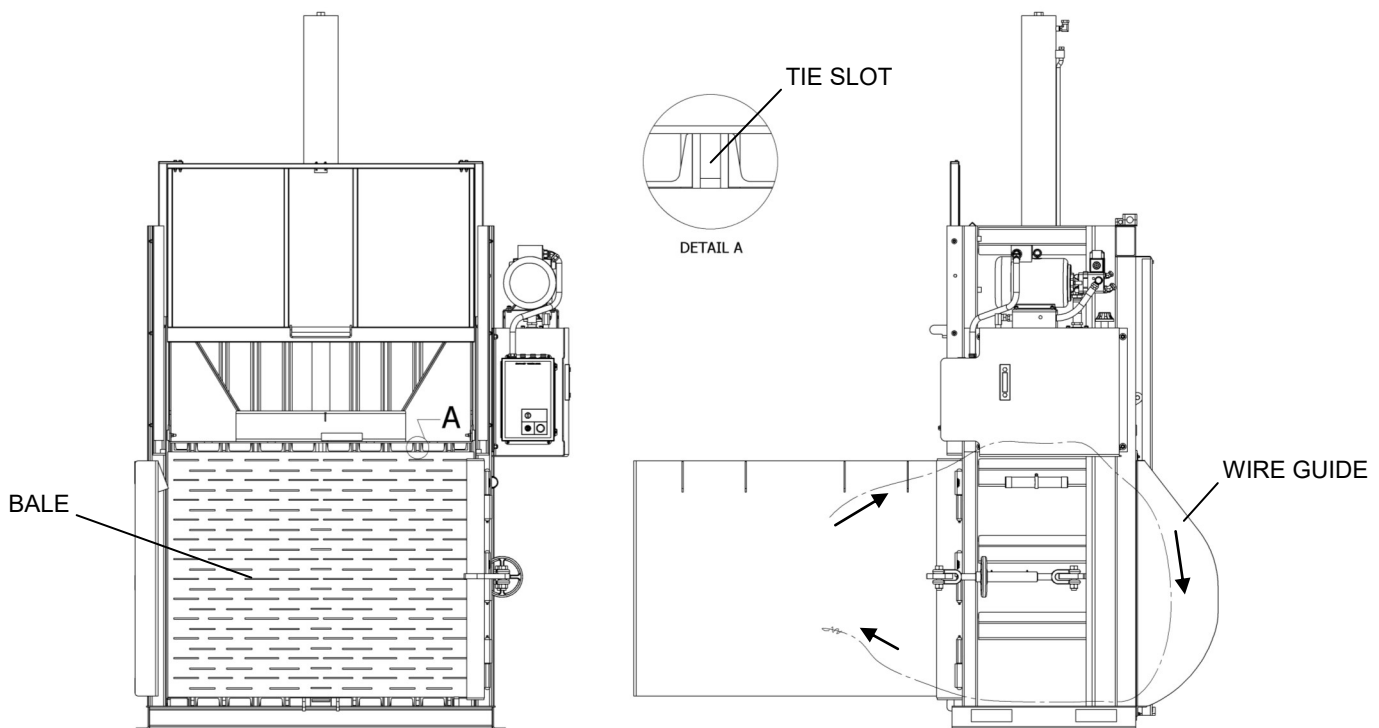

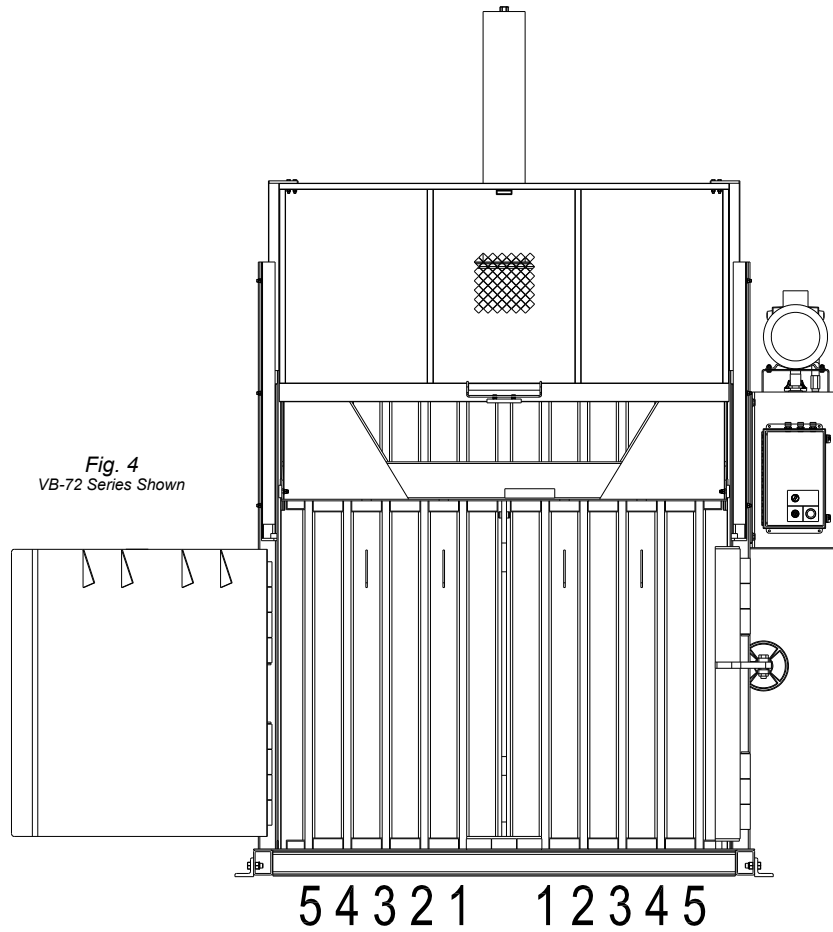

Fig. 6  
VB-60 Series Shown

## Ejecting a Bale

1. Ensure that all personnel and obstructions have been cleared from the area around the baler.
2. Prepare an area in the front of the baler to eject the bale.
3. With the mode selector switch in "MANUAL UP" engage the bale eject system by pressing in on the bale eject handle.
4.  Insert the key into the start switch and turn to the "START" position. The motor will start but the presshead will not move.
5. CAUTION! Do not stand in front of the baler while ejecting the bale!
6. Remove the key. Pull and hold the Stop / Pull to Raise button to raise the presshead and eject the bale.
7. Remove the ejected bale and clean any loose material from inside the chamber.
8. Close and latch the chamber door using the turnbuckle on the chamber door latch.
9. Close the loading door.
10. To reset the bale eject system, turn the mode selector switch to "AUTO", insert the key into the start switch and turn to the "START" position until the presshead begins to descend. The Bale Eject Handle will disengage automatically during the downstroke.
11. Remove the key. At the end of the cycle, the baler will stop and the loading door will open.

# Baler Operation, cont.



Material Type	Model Number	Recommended Bale Tie Configuration
Corrugated Cardboard	VB-42 Series	Use tie slots 1, 2, & 3
	VB-60 Series	Use tie slots 1, 3, & 4
	VB-72 Series	Use tie slots 1, 3, 4, & 5
Shrink Wrap Plastic	VB-42 Series	Use tie slots 1, 2, & 3
	VB-60 Series	Use tie slots 1, 2, 3, & 4
	VB-72-Series	Use tie slots 1, 2, 3, 4, & 5
Plastic Bottles	VB-42 Series	Use tie slots 1, 2, & 3
	VB-60-Series	Use tie slots 1, 2, 3, & 4
	VB-72 Series	Use tie slots 1, 2, 3, 4, & 5
Aluminum Cans	VB-42 Series	Use tie slots 1, 2, & 3
	VB-60 Series	Use tie slots 1, 3, & 4
	VB-72 Series	Use tie slots 1, 3, 4, & 5

Reference Parts page for bale ties.

# ***Maintenance***



## **CAUTION**

Before performing any maintenance, always "LOCK AND TAG OUT THE DISCONNECT."

### ***Lock Out / Tag Out Procedures***

This procedure establishes the **minimum** requirements for the lockout of your baler for service. It shall be used to ensure that the machine is isolated from all potentially hazardous energy, and locked out before employees perform any servicing or maintenance activities where the unexpected energization or start-up could cause serious injury or fatality due to electrocution or due to entrapment in moving parts. This procedure should be performed only by an authorized, qualified electrician.

1. Before locking baler out for service or repair, locate which breaker or disconnect applies to the baler to be locked out. Notify all affected employees that a lockout system is going to be utilized and the reason therefore.
2. If the machine or equipment is operating, shut it down by the normal stopping procedure.
3. Lock out the disconnect or breaker that controls the baler. If locking out a breaker use a double-pole breaker lockout and lock.
4. Lockout the energy isolating devices with assigned individual locks. If more than one person is servicing the baler, then a hasp with a lock for each service person shall be used.
5. After ensuring that no personnel are exposed, and as a check on having closed the appropriate breaker or disconnect, operate the start button to make certain the baler will not operate. Then push the stop button. The baler is now locked out.
6. After the servicing and/or maintenance is complete and equipment is ready for normal production operations, check the area around the machines or equipment to ensure that no one is exposed.
7. After all tools have been removed from the baler and employees are in the clear, remove the lockout device. Operate the start button to restore energy to the baler .

# Maintenance, cont.

## Chocking the Presshead

Before entering the bale chamber to perform any service tasks, the presshead should be chocked in conjunction with following the Lock Out / Tag Out procedures as described on the previous page. The presshead should be supported with two 4"x4" wooden beams that are in excellent condition. DO NOT use the wood if its integrity is questionable. The beams should be cut to length so they fit tightly in between the presshead and the baler floor when the presshead is fully raised (see figure 5). The top of the beams should be placed in the rear-most corner on each side of the baler. The bottom of the beams should be positioned into the outermost bale tie slot in the baler floor as illustrated below.

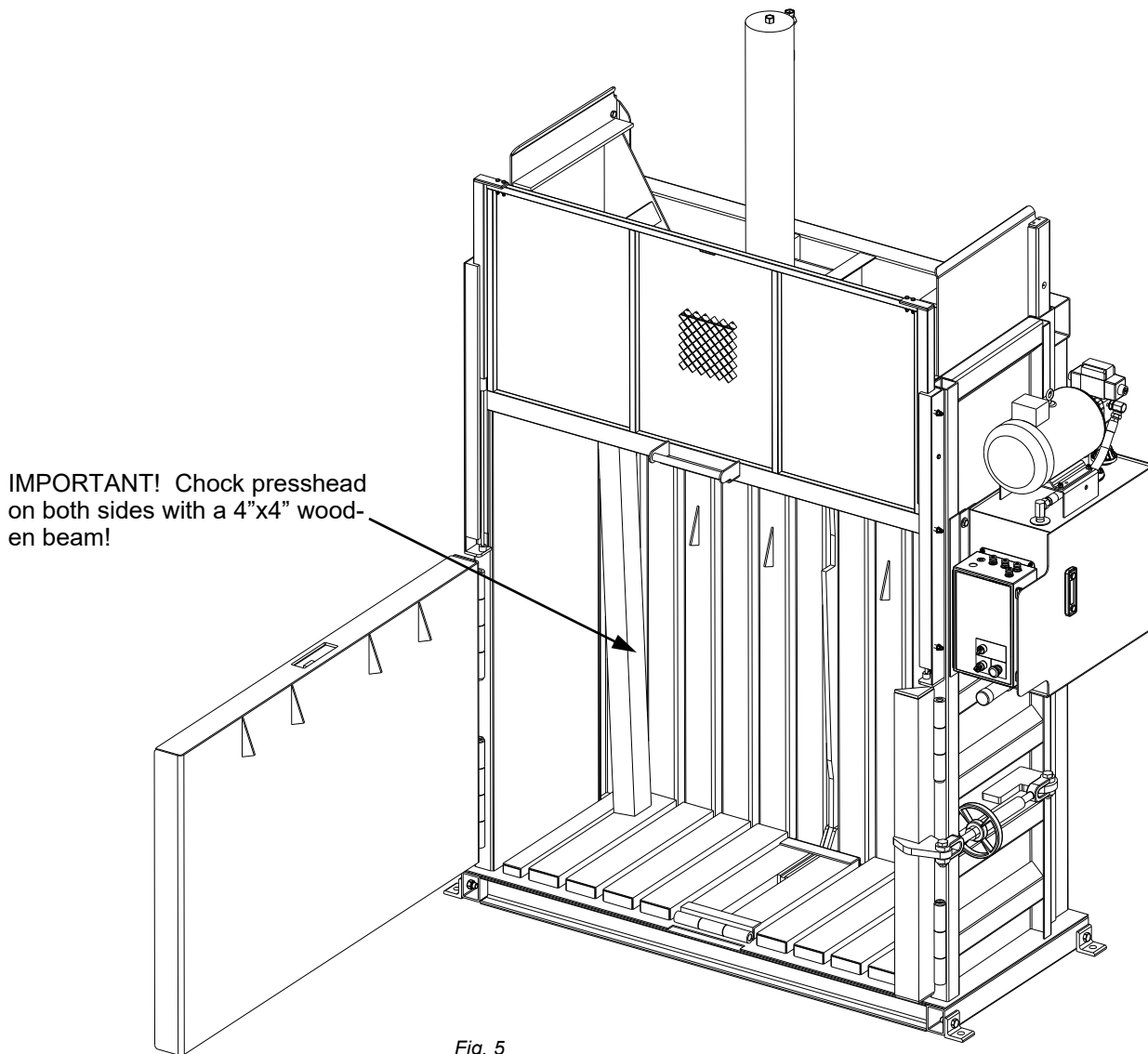

Fig. 5

# Maintenance, cont.

## Preventive Maintenance Schedule

Starting and adhering to a comprehensive preventive maintenance program will ensure and extend the trouble-free operation of your baler. Particular attention should be given to the maintenance of the hydraulic system to extend the life of the baler.

### Daily

- Clean any loose material from the top of the presshead.
- Clean any loose material from the tie slots in the floor of the bale chamber and underneath the dump tray after dumping each bale. Follow Lock out / Tag out procedures and Presshead Chocking procedures as specified elsewhere in this manual.
- Clean the surface of the magnetic door latch and striker with a clean cloth.

### Monthly

- Lubricate the chamber door hinges.
- Lubricate dump handle bushings.
- Grease the turnbuckle for the chamber door latch.
- Check the oil level with the presshead fully raised.
- Check all hydraulic hoses for rubbing, chafing, deterioration, damage, and leaks.
- Check all hydraulic fittings for loosening and leaks.
- Check that all safety decals are present and legible.

### Annually

We recommend having a CRAM-A-LOT® Factory Authorized Service Technician perform the annual preventive maintenance check. To coordinate a PM Check through CRAM-A-LOT® Customer Support, call 1-800-754-4290.

- Replace the hydraulic oil.
- Check presshead guides for wear and adjust appropriately.
- Check the cylinder mounting bolts for tightness.

Preventive Maintenance History		
Date	Performed By	Maintenance Interval Performed
1/1/03	Joe Fixit	<input checked="" type="checkbox"/> Monthly <input type="checkbox"/> Annual
		<input type="checkbox"/> Monthly <input type="checkbox"/> Annual
		<input type="checkbox"/> Monthly <input type="checkbox"/> Annual
		<input type="checkbox"/> Monthly <input type="checkbox"/> Annual
		<input type="checkbox"/> Monthly <input type="checkbox"/> Annual
		<input type="checkbox"/> Monthly <input type="checkbox"/> Annual
		<input type="checkbox"/> Monthly <input type="checkbox"/> Annual
		<input type="checkbox"/> Monthly <input type="checkbox"/> Annual
		<input type="checkbox"/> Monthly <input type="checkbox"/> Annual
		<input type="checkbox"/> Monthly <input type="checkbox"/> Annual
		<input type="checkbox"/> Monthly <input type="checkbox"/> Annual
		<input type="checkbox"/> Monthly <input type="checkbox"/> Annual
		<input type="checkbox"/> Monthly <input type="checkbox"/> Annual
		<input type="checkbox"/> Monthly <input type="checkbox"/> Annual
		<input type="checkbox"/> Monthly <input type="checkbox"/> Annual
		<input type="checkbox"/> Monthly <input type="checkbox"/> Annual

# Maintenance, cont.

## Safety Decals

It is the responsibility of the owner / operator to ensure that all safety decals on the baler remain legible and complete. Please refer to the section titled “Safety Orientation” for more information on the importance of these decals. If a decal becomes illegible or lost, it may be ordered from CRAM-A-LOT® Customer Support using the part numbers provided below.

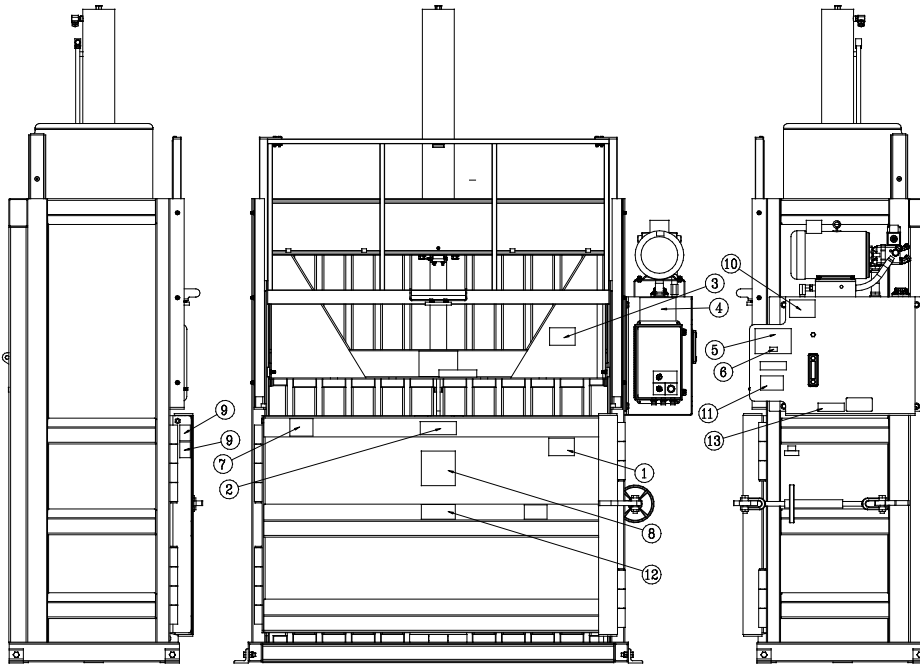

Item	Part Number	Decal Description
1	443005	“DANGER—Do Not Enter”
2	443017	“WARNING—Magnetic Field. Pacemaker wearers stay back.”
3	443012	“DANGER—Crushing Hazard”
4	443013	“DANGER—Disconnect and Lock Out Power Before Opening this Panel”
5	443007	“DANGER—XXX VOLTS. Turn off Power Before Disconnecting”
6	440003	Red decal that indicates the voltage of the machine—placed on top of Item 5
7	440075	“WARNING—Maximum Load Height”
8	443001	“WARNING—Do Not Load, Operate, or Unload Unless 18 Years Old”
9	440820	“DANGER—Pinch Point”
10	443009	“WARNING—Keep off Vertical”
11	443000	“WARNING—Do not Operate”
12	440455	“CAUTION—Operator 18yrs”
13	443014	“WARNING—Shock Arc Hazard”

Call CRAM-A-LOT® Customer Support at 1-800-754-4290 to order decals.

# Maintenance, cont.

## Checking and Adding Oil

**Time:** 30 minutes

**Tools:** Eight foot step ladder, clean funnel

**Parts:** SAE 5W-20 high grade hydraulic oil (Sun 2105 or equivalent)

**Supplies:** Disposable shop towels

- Tips:**
- Make sure that the presshead is fully raised when checking and filling the oil.
  - Be patient when filling the oil.
  - The cleanliness of the oil is very important to the long term reliability of the hydraulic system.

### Checking the Oil Level

1. Run the machine to place the presshead in the fully raised position.
2. Check the oil by looking at the sight gauge on the side of the oil tank. If the oil level is below the black fill line on the gauge, oil needs to be added to the tank.

### Adding Oil

3. **IMPORTANT!** - Follow all Lock out / Tag out procedures before continuing this service procedure.
4. Place the step ladder in front of the power unit and use it to reach the top of the oil tank.
5. Using a disposable shop towel, clean any dust and debris from around the oil fill port to prevent contaminants from entering the hydraulic system.
6. Remove the vent cap on the oil fill port.
7. Using a clean funnel, pour oil into the fill port until the oil level has reached the black fill line on the oil sight gauge.
8. When the oil level reaches the black fill line, remove the funnel, replace the vent cap into the oil fill port.
9. Clean any spilled oil off of the machine with a disposable shop towel.
10. Remove the lock out / tag out according to procedures and restore power to the unit.
11. Check unit operation.

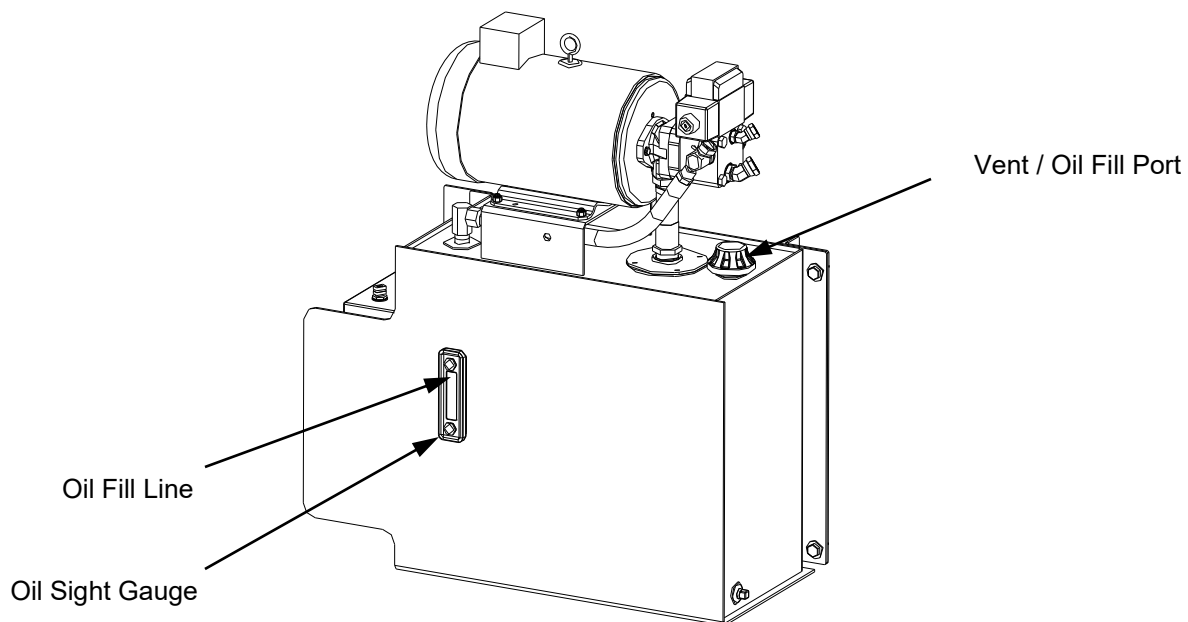

Fig. 7

# Troubleshooting

If your cardboard baler is not operating properly, there are a few areas that can be checked before requesting a service technician to come repair the machine. To save downtime and the cost of an unnecessary service call, use the following guide to troubleshoot the machine before calling service. Do not attempt to service the machine in areas beyond the scope of this troubleshooting guide. Call 1-800-754-4290 for repairs.

## **The motor won't start when the key is turned.**

1. Ensure that the emergency stop switch is not engaged.
2. Ensure that the loading door is fully closed if the baler is in "Auto" or "Manual Down" mode.
3. Ensure that the loading door is open if the baler is in "Manual Up" mode.
4. Ensure that the electromagnetic door latch and striker surfaces are clean.
5. Ensure that the disconnect or circuit breaker is turned on.
6. If the motor still won't start, call *CRAM-A-LOT*® Customer Support for repairs.

## **The motor runs but the presshead won't move.**

### **If you are operating the baler in the "Manual Up" mode:**

1. In "Manual Up" mode, it is necessary to pull out on the emergency stop switch to raise the presshead.
2. If the presshead still won't raise, call *CRAM-A-LOT*® Customer Support for repairs.

### **If you are operating the baler in the "Auto" or "Manual Down" modes:**

3. Ensure that the loading door is fully closed.
4. Ensure that the electromagnetic door latch and striker surfaces are clean.
5. Ensure that the chamber door is fully closed.
6. If the presshead still won't move, call *CRAM-A-LOT*® Customer Support for repairs.

## **The loading door won't open so material can be loaded.**

1. Turn the key to the "Off" position and the loading door should raise automatically.
2. If the door still won't raise, call *CRAM-A-LOT*® Customer Support for repairs.

## **The loading door won't stay closed.**

1. Ensure that the key is turned to the "On" position.
2. Ensure that the emergency stop switch is not engaged.
3. Ensure that the mode selector switch is in the "Auto" or "Man Down" positions.
4. Ensure that the electromagnetic door latch and striker surfaces are clean.
5. Ensure that the chamber door is fully closed.
6. If the door still won't stay closed, call *CRAM-A-LOT*® Customer Support for repairs.

## **The bale ties won't go through the slots in the floor or presshead to tie a bale.**

1. Ensure that the chamber door is open.
2. Ensure that the correct end of the bale tie is being guided through the slots.
3. Ensure that a full sheet of cardboard has been laid on the chamber floor before the bale was made.
4. Ensure that a full sheet of cardboard has been laid on top of the full bale before the presshead was lowered.
5. If the problem persists, call *CRAM-A-LOT*® Customer Support for additional guidance.

## **The bale won't eject.**

1. Ensure that the dump handle was engaged before the machine was operated in the "Manual Up" mode to dump the bale.
2. On newer balers, the paint on the inside of the bale chamber may prevent the bale from ejecting well. The bales will eject more easily as each consecutive bale is ejected.
3. While ejecting the bale the motor may shut off. If this occurs, the baler cycle timer has timed out. Simply turn the key switch to restart the baler and proceed with ejecting the bale.
4. If the bale will still not eject properly, call *CRAM-A-LOT*® Customer Support for repairs.

# ***Troubleshooting cont.***

## **PICOVB07 TROUBLESHOOTING GUIDE**

POSSIBLE PROBLEM	ERROR DISPLAYED	CODE	RECOMMENDATION
The Baler will not start.	STOP BUTTON IS IN THE “STOP” POSITION	1	<ul style="list-style-type: none"> <li>● Pull the STOP button out to the “RUN” position.</li> </ul>
	ELECTROMAGNETIC LOCK FAILED “OPEN”	2	<ul style="list-style-type: none"> <li>● Close and latch the Loading Door.</li> <li>● Check the Door Position Sensor for proper alignment to the magnet on the Door Strike Plate.</li> <li>● Check the Electromagnetic Lock.</li> <li>● Replace the Electromagnetic Lock.</li> </ul>
	ELECTROMAGNETIC LOCK FAILED “CLOSED”	3	<ul style="list-style-type: none"> <li>● Cycle power to unlock the Loading Door.</li> <li>● Close and latch the Loading Door.</li> <li>● Check the Door Position Sensor for proper alignment to the magnet on the Door Strike Plate.</li> <li>● Check the Electromagnetic Lock.</li> <li>● Replace the Electromagnetic Lock.</li> </ul>
When you release the key the Baler stops.	UPPER MAGNETIC INTERLOCK SWITCH FAILED “OPEN”	4	<ul style="list-style-type: none"> <li>● Close and latch the Loading Door.</li> <li>● Check the Upper Magnetic Interlock Switch for proper alignment to the magnet on the Loading Door.</li> <li>● Check the Upper Magnetic Interlock Switch.</li> <li>● Replace the Upper Magnetic Interlock Switch.</li> </ul>
When the ram retracts to the top, the Baler continues to run.	UPPER MAGNETIC INTERLOCK SWITCH FAILED “CLOSED”	5	<ul style="list-style-type: none"> <li>● Check the Upper Magnetic Interlock Switch mounting bracket for proper operation.</li> <li>● Check the Upper Magnetic Interlock Switch.</li> <li>● Replace the Upper Magnetic Interlock Switch.</li> </ul>
The Baler will not start.	MOTOR STARTER FAILED	6	<ul style="list-style-type: none"> <li>● Check the Motor Starter Overload and press “RESET” if necessary.</li> <li>● Check power to the Motor Starter coil.</li> <li>● Replace Motor Starter.</li> </ul>

# Technical Specifications

## Standard Models

Model		VB-42-B	VB-60-B	VB-60-T	VB-60-H	VB-60-X	VB-72-B	VB-72-T	VB-72-H	VB-72-X
<b>A</b>	Feed Opening Height in (mm)	24 (610)	24 (610)	24 (610)	24 (610)	24 (610)	24 (610)	24 (610)	24 (610)	24 (610)
<b>B</b>	Load Height in (mm)	52 (1321)	52 (1321)	52 (1321)	52 (1321)	52 (1321)	52 (1321)	52 (1321)	52 (1321)	52 (1321)
<b>C</b>	Overall Width in (mm)	64 (1626)	82 (2083)	82 (2083)	82 (2083)	82 (2083)	94 (2388)	94 (2388)	94 (2388)	94 (2388)
<b>D</b>	Overall Depth in (mm)	40.5 (1029)	40.5 (1029)	40.5 (1029)	40.5 (1029)	40.5 (1029)	40.5 (1029)	40.5 (1029)	40.5 (1029)	40.5 (1029)
<b>E</b>	Overall Depth Door open in (mm)	85 (2159)	97 (2464)	97 (2464)	97 (2464)	97 (2464)	109 (2769)	109 (2769)	109 (2769)	109 (2769)
<b>F</b>	Frame Height in (mm)	98.5 (2502)	98.5 (2502)	98.5 (2502)	98.5 (2502)	98.5 (2502)	98.5 (2502)	98.5 (2502)	98.5 (2502)	98.5 (2502)
<b>G</b>	Overall Height Installed in (mm)	138 (3512)	138 (3512)	145.5 (3696)	145.5 (3696)	145.5 (3696)	138 (3512)	145.5 (3696)	145.5 (3696)	145.5 (3696)
Nominal Bale Size in (mm)	<b>W</b>	42 (1067)	60 (1524)	60 (1524)	60 (1524)	60 (1524)	72 (1829)	72 (1829)	72 (1829)	72 (1829)
	<b>D</b>	30 (762)	30 (762)	30 (762)	30 (762)	30 (762)	30 (762)	30 (762)	30 (762)	30 (762)
	<b>H</b>	48 (1219)	48 (1219)	48 (1219)	48 (1219)	48 (1219)	48 (1219)	48 (1219)	48 (1219)	48 (1219)
Bale Weight (OCC) Up To lb (kg)		750 (340)	1,000 (454)	1,200 (544)	1,400 (635)	1,400 (635)	1,200 (544)	1,400 (635)	1,600 (726)	1,600 (726)
Cylinder in (mm)	<b>B</b>	6 (152)	6 (152)	6 (152)	7 (178)	7 (178)	6 (152)	6 (152)	7 (178)	7 (178)
	<b>S</b>	44 (1118)	44 (1118)	52 (1321)	52 (1321)	52 (1321)	44 (1118)	52 (1321)	52 (1321)	52 (1321)
	<b>R</b>	3.5 (89)	3.5 (89)	4 (102)	4 (102)	4 (102)	3.5 (89)	4 (102)	4 (102)	4 (102)
Motor hp (kw)		10 (7.5)	10 (7.5)	15 (11.2)	15 (11.2)	20 (14.9)	10 (7.5)	15 (11.2)	15 (11.2)	20 (14.9)
Pump @1800 rpm Gpm (l/min)		9 (34)	9 (34)	10.5 (40)	10.5 (40)	13.5 (51)	9 (34)	10.5 (40)	10.5 (40)	13.5 (51)
System Pressure psi (BAR)		2100 (145)	2100 (145)	2400 (165)	2400 (165)	2400 (165)	2100 (145)	2400 (165)	2400 (165)	2400 (165)
Platen Force lbs (kN)		59,370 (264)	59,370 (264)	67,850 (302)	92,350 (410)	92,350 (410)	59,370 (264)	67,850 (302)	92,350 (410)	92,350 (410)
Platen Face Pressure psi (kPa)		81 (558)	45 (310)	51 (352)	69 (476)	69 (476)	37 (255)	42 (290)	57 (393)	57 (393)
Average Cycle Time sec		53	53	50	74	58	53	50	74	58
(W/Optional Regen)		32	32	31	57	45	32	31	57	45
Unit Weight lb (kg)		4,600 (2087)	4,700 (2132)	4,800 (2177)	4,800 (2177)	4,800 (2177)	5,600 (2540)	5,700 (2585)	5,700 (2585)	5,700 (2585)

# Technical Specifications

## Special Models

Model		VB-42-B-LP	VB-60-B-LP	VB-60-H-DC	VB-60-H-LP	VB-72-B-LP	VB-72-H-DC	VB-72-H-LP
<b>A</b>	Feed Opening Height in (mm)	24 (610)	24 (610)	24 (610)	24 (610)	24 (610)	24 (610)	24 (610)
<b>B</b>	Load Height in (mm)	42 (1067)	42 (1067)	52 (1321)	42 (1067)	42 (1067)	52 (1321)	42 (1067)
<b>C</b>	Overall Width in (mm)	64(1626)	82 (2083)	82 (2083)	82 (2083)	94 (2388)	94 (2388)	94 (2388)
<b>D</b>	Overall Depth in (mm)	40.5 (1029)	40.5 (1029)	52.5 (1334)	40.5 (1029)	40.5 (1029)	52.5 (1334)	40.5 (1029)
<b>E</b>	Overall Depth Door open in (mm)	85 (2159)	97 (2464)	109 (2769)	97 (2464)	109 (2769)	121 (3075)	109 (2769)
<b>F</b>	Frame Height in (mm)	88.5 (2248)	88.5 (2248)	98.5 (2502)	88.5 (2248)	88.5 (2248)	98.5 (2502)	88.5 (2248)
<b>G</b>	Overall Height Installed in (mm)	118 (2997)	118 (2997)	145.5 (3696)	121.5 (3086)	118 (2997)	145.5 (3696)	121.5 (3086)
Nominal Bale Size in (mm)	<b>W</b>	42 (1067)	60 (1524)	60 (1524)	60 (1524)	72 (1829)	72 (1829)	72 (1829)
	<b>D</b>	30 (762)	30 (762)	42 (1067)	30 (762)	30 (762)	42 (1067)	30 (762)
	<b>H</b>	38 (965)	38 (965)	48 (1219)	38 (965)	38 (965)	48 (1219)	38 (965)
Bale Weight (OCC) Up To lb (kg)		650 (295)	800 (363)	1600 (726)	1100 (499)	950 (431)	1800 (816)	1250 (567)
Cylinder in (mm)	<b>B</b>	6 (152)	6 (152)	7 (178)	7 (178)	6 (152)	7 (178)	7 (178)
	<b>S</b>	34 (864)	34 (864)	52 (1321)	38 (965)	34 (864)	52 (1321)	38 (965)
	<b>R</b>	3.5 (89)	3.5 (89)	4 (102)	4 (102)	3.5 (89)	4 (102)	4 (102)
Motor hp (kw)		10 (7.5)	10 (7.5)	15 (11.2)	15 (11.2)	10 (7.5)	15 (11.2)	15 (11.2)
Pump @1800 rpm Gpm (l/min)		9 (34)	9 (34)	10.5 (40)	10.5 (40)	9 (34)	10.5 (40)	10.5 (40)
System Pressure psi (BAR)		2100 (145)	2100 (145)	2400 (165)	2400 (165)	2100 (145)	2400 (165)	2400 (165)
Platen Force lbs (kN)		59,370 (264)	59,370 (264)	92,350 (410)	92,350 (410)	59,370 (264)	92,350 (410)	92,350 (410)
Platen Face Pressure psi (kPa)		81 (558)	45 (310)	51 (352)	69 (476)	37 (255)	41 (283)	57 (393)
Average Cycle Time sec		43	43	74	55	43	74	55
(W/Optional Regen)		26	26	57	34	26	57	34
Unit Weight lb (kg)		4,200 (1909)	4,700 (2132)	5,300 (2404)	4,800 (2177)	5,600 (2540)	6,400 (2903)	5,700 (2585)

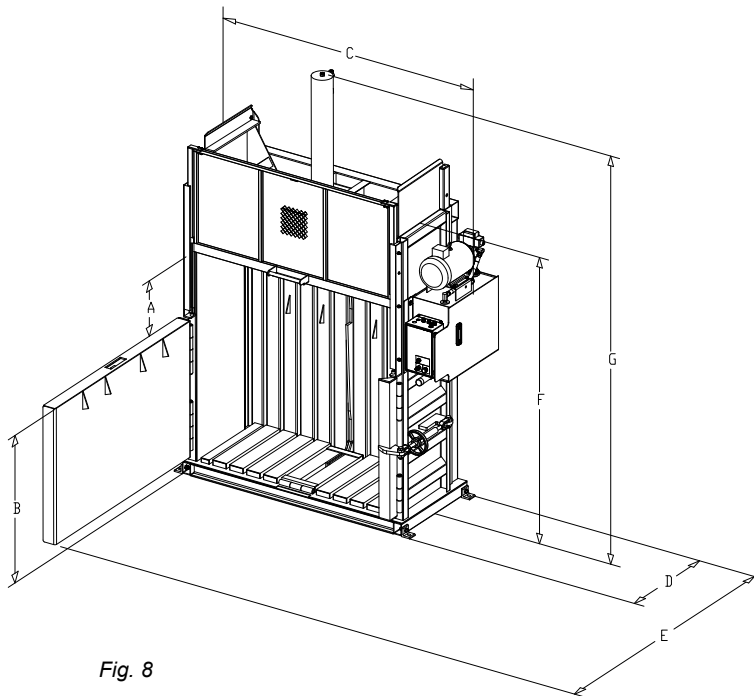

Fig. 8

# Parts Diagrams

## Chassis & Loading Door

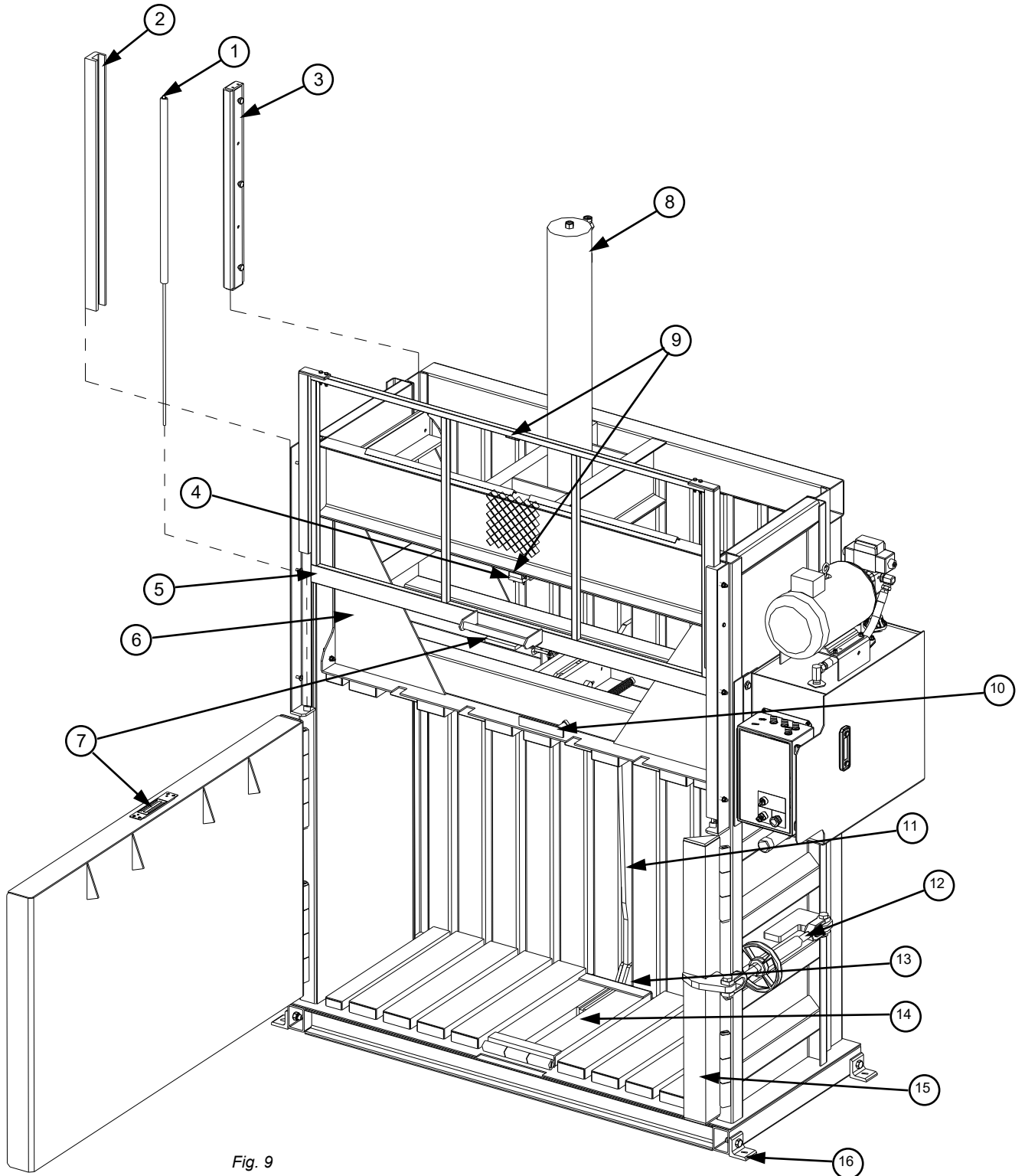

Fig. 9

# Parts Diagrams, cont.

## Chassis & Loading Door

Item	Part Number	Part Description	Notes
1	136000	Gas Shock for Loading Door (Sold individually.)	
2	VBG00053	Loading Door Guide (Sold individually.)	
3	VB00P350	Presshead guide (Sold individually.)	
	VB00P352	Presshead guide (Sold individually). for VB-42-B, VB-60-B, VB-72-B *	
4	VB00M208	Magnetic Safety Switch bracket, hinge, and installation hardware	
5	VB42G150	Loading Door for VB-42 Series balers	
	VB60G150	Loading Door for VB-60 Series balers	
	VB72G150	Loading Door for VB-72 Series balers	
	VB182	Loading Door for VB-42-LP	
	VB183	Loading Door for VB-60-LP	
6	VB184	Loading Door For VB-72-LP	
	VB42P150	Presshead for VB-42-B	(manufactured 9-01-2007 to 1-17-2013)
	VB174	Presshead for VB-42-B	(manufactured 1-17-2013 and after)
	VB42P151	Presshead for VB-42-H	
	VB60P150	Presshead for VB-60-B, VB-60-B-LP	(manufactured 9-01-2007 to 1-17-2013)
	VB167	Presshead for VB-60-B	(manufactured 1-17-2013 and after)
	VB60P151	Presshead for VB-60-T, VB-60-H, and VB-60-X	
	VB60P153	Presshead for VB-60-H-DC	
	VB72P150	Presshead for VB-72-B	(manufactured 9-01-2007 to 1-17-2013)
	VB165	Presshead for VB-72-B	(manufactured 1-17-2013 and after)
7	VB72P151	Presshead for VB-72-T, VB-72-H, VB-72-X	
	VB72P153	Presshead for VB-72-H-DC	
	260060	Magnetic Door Latch, Striker Plate, and installation hardware	
8	VKT00046	Cylinder and pin asm for VB-42-B, VB-60-B, and VB-72-B	
	VKT00052	Cylinder and pin asm for VB-60-T, VB-72-T	
	VKT00053	Cylinder and pin asm for VB-60-H, VB-60-X, VB-72-H, VB-72-X	
	VKT00054	Cylinder and pin asm for VB-60-B-LP, VB-72-B-LP	
	VKT00055	Cylinder and pin asm for VB-60-H-LP, VB-72-H-LP	
9	260004	Magnetic Safety Switch	
10	VB101	Dump Handle for all VB Series balers except: VB-60-H-DC, VB-72-H-DC	
	VB103	Dump Handle for VB-60-H-DC, VB-72-H-DC	
11	VB00K111	Dump Hook for all VB Series balers except: VB-60-B-LP, VB-72-B-LP	
	VB00K113	Dump Hook for VB-60-B-LP, VB-72-B-LP	
12	380030	Turnbuckle for chamber door latch	
13		Bolt 1/2x3 and Lock nut 1/2	
14	VB152	Dump Tray for all models VB Series balers except: VB-60-H-DC, VB-72-H-DC	(manufactured 9-01-2007 and after)
	VB00K112	Dump Tray for VB-60-H-DC, VB-72-H-DC	
15	VB00L100	Chamber Door Latch for all VB Series balers except: VB-60-B-LP, VB-72-B-LP	(manufactured 9-01-2007 to 1-17-2013)
	VB168	Chamber Door Latch for VB-42-B, VB-60-B, VB-72-B	(manufactured 1-17-2013 and after)
	VB00L101	Chamber Door Latch for VB-60-B-LP, VB-72-B-LP	
16	VBM00030	Anchor pads (Sold Individually)	

Bale Ties (Not Shown)		
Part Number	Part Description	Application
391016	14 ga x 14' Bale ties (250 ties)	Standard and Low Profile VB Series Balers
391025	12 ga x 18' Bale ties (125 ties)	VB Series Deep Chamber Balers
391018	12 ga x 14' Bale ties (125 ties)	For baling plastics

Call **CRAM-A-LOT**® Customer Support at 1-800-754-4290 to order parts.

# Parts Diagrams, cont.

## Power Unit

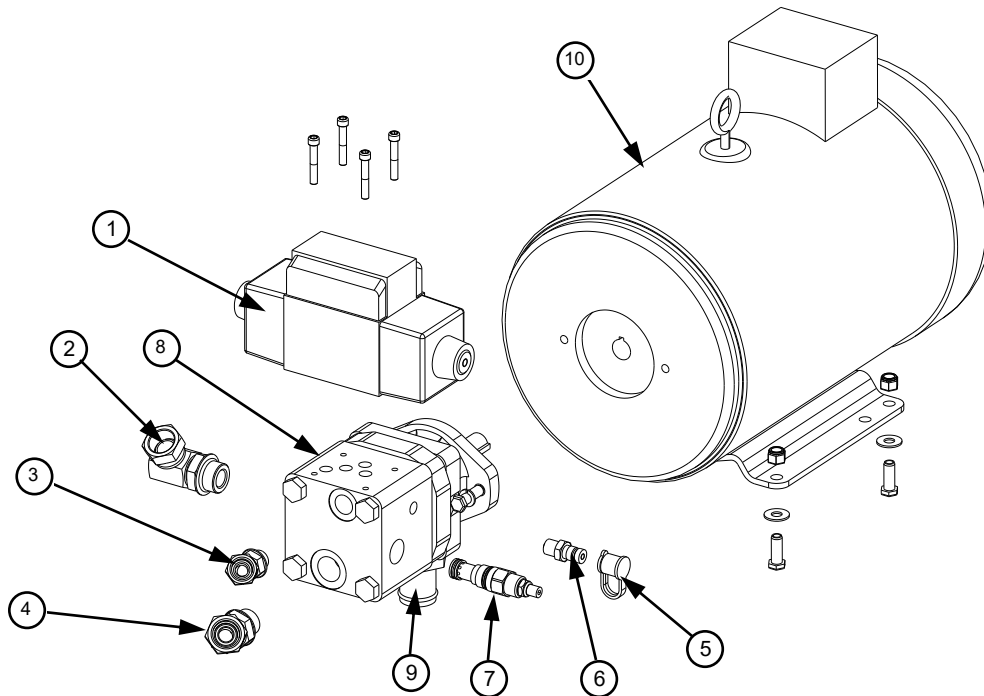

Fig. 10

Item	Part Number	Part Description
1	00140001	Directional Valve
	00140002	Directional Valve
2	00163006	3/4" x 3/4" 90° Swivel Fitting (Male SAE to Female NPT)
3	00163023	1/2" x 1/2" 45° Swivel Fitting (Male SAE to Female NPT)
4	00163025	45° Swivel Fitting
5	00151625	Quick Disconnect Dust Cap
6	00151519	1/4" Male Quick Disconnect
7	00153101	Relief Valve
8	00120060	Pump for VB-42-B, VB-60-B, VB-72-B (Including LP versions)
	00120062	Pump for VB-42-H, VB-60-T, VB-60-H, VB-72-T, VB-72-H (Including LP and DC versions)
	00120064	Pump for VB-60-X, VB-72-X
9	00162524	Slip-on Fitting
10	00112518	Three Phase Motor for VB-42-B, VB-60-B, VB-72-B (Including LP versions)
	00113012	Three Phase Motor for VB-42-H, VB-60-T, VB-60-H, VB-72-T, VB-72-H (Including LP and DC versions)
	00113507	Three Phase Motor for VB-60-X, VB-72-X
	00112503	Single Phase Motor for VB-42-B, VB-60-B, VB-72-B (Including LP versions)
Not Shown	00150210	Suction Hose: 1 1/4" x 12 7/8" (From tank to Item 9)
Not Shown	00151145	Return Hose: 3/4" x 20" (From tank to Item 2)
Not Shown	00151149	Extend Hose: 3/4" x 145" (From cylinder to Item 2)
Not Shown	00151048	Retract Hose: 1/2" x 141" (From cylinder to Item 3)
Not Shown	00820553	DIN Plugs for directional valve
Not Shown	00140507	Oil shutoff ball valve

Call **CRAM-A-LOT**® Customer Support at 1-800-754-4290 to order parts.

# Parts Diagrams, cont.

## Hydraulic Tank & Operators

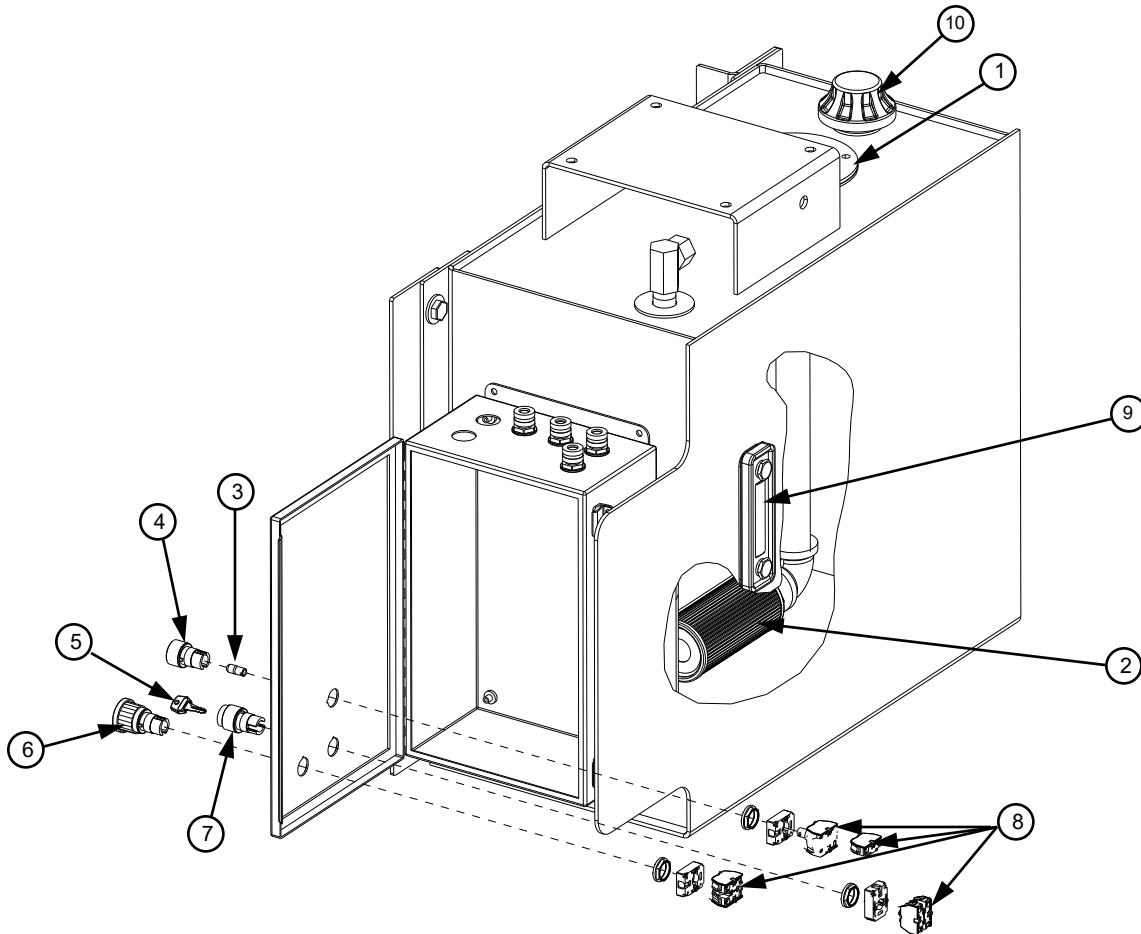

Fig. 11

Item	Part Number	Part Description
1	VKT00038	Filter cap, fill plug, and hardware
2	166534	Replacement Filter
3	20218693	Replacement light bulb for Mode Selector Switch
4	20218692	Illuminated Mode Selector Switch
5	280185	Replacement key
6	20218710	Emergency stop switch (Pull to raise)
7	20218690	Key Switch
8	20218625	Green Contact Block (normally open)
	20218630	Red Contact Block (normally closed)
	20218640	Clear Contact Block (normally closed, late break)
	20218635	Orange Contact Block (normally open, early make)
9	190020	Oil Level Gauge
10	121520	Vented Cap

Call **CRAM-A-LOT**® Customer Support at 1-800-754-4290 to order parts.

# Parts Diagrams, cont.

## Control Panel

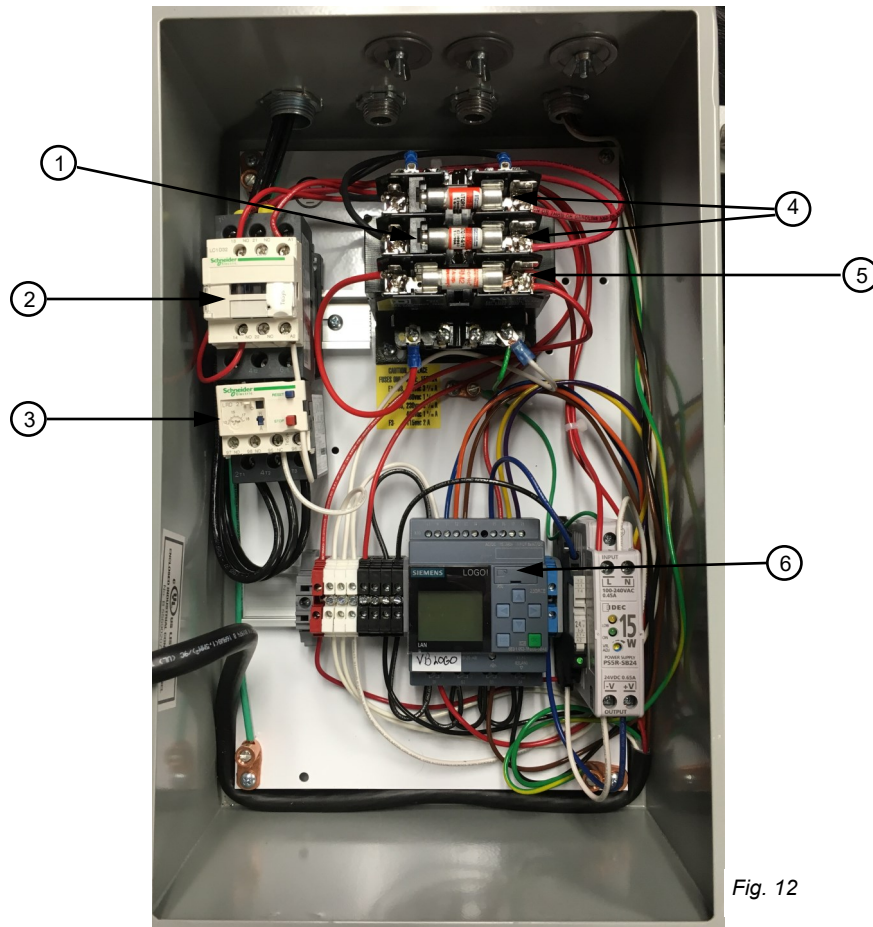

Fig. 12

Item	Part Number	Part Description
1	20214001	Voltage Transformer
2	00261046	Motor Starter for VB-**-B Series balers (Including LP versions)
	00261055	Motor Starter for VB-**-T, VB-**-H Series balers operating at 230 or 460 volts (Including LP and DC versions)
	00261050	Motor Starter for VB-**-T, VB-**-H Series balers operating at 208 volts (Including LP and DC versions)
	00261050	Motor Starter for VB-**-X Series balers
3	00266561	Overload for VB-**-B Series balers operating at 208 or 230 volts (Including LP versions)
	20213735	Overload for VB-**-B Series balers operating at 460 volts (Including LP versions)
	00266545	Overload for VB-**-T, VB-**-H Series balers operating at 208 or 230 volts (Including LP and DC versions)
	00266523	Overload for VB-**-T, VB-**-H Series balers operating at 460 volts (Including LP and DC versions)
	00266550	Overload for VB-**-X Series balers operating at 208 or 230 volts
	00266540	Overload for VB-**-X Series balers operating at 460 volts
4	20211047	Primary Fuse for machines operating at 208 or 230 volts (NQR-3-2/10)
	20211031	Primary Fuse for machines operating at 480 volts (FNQR-1-6/10)
5	20211046	Secondary Fuse for all machines (FNM-2)
6	20215530	Programmable Relay

Call **CRAM-A-LOT**® Customer Support at 1-800-754-4290 to order parts.

# Electrical Schematic

Fig. 13

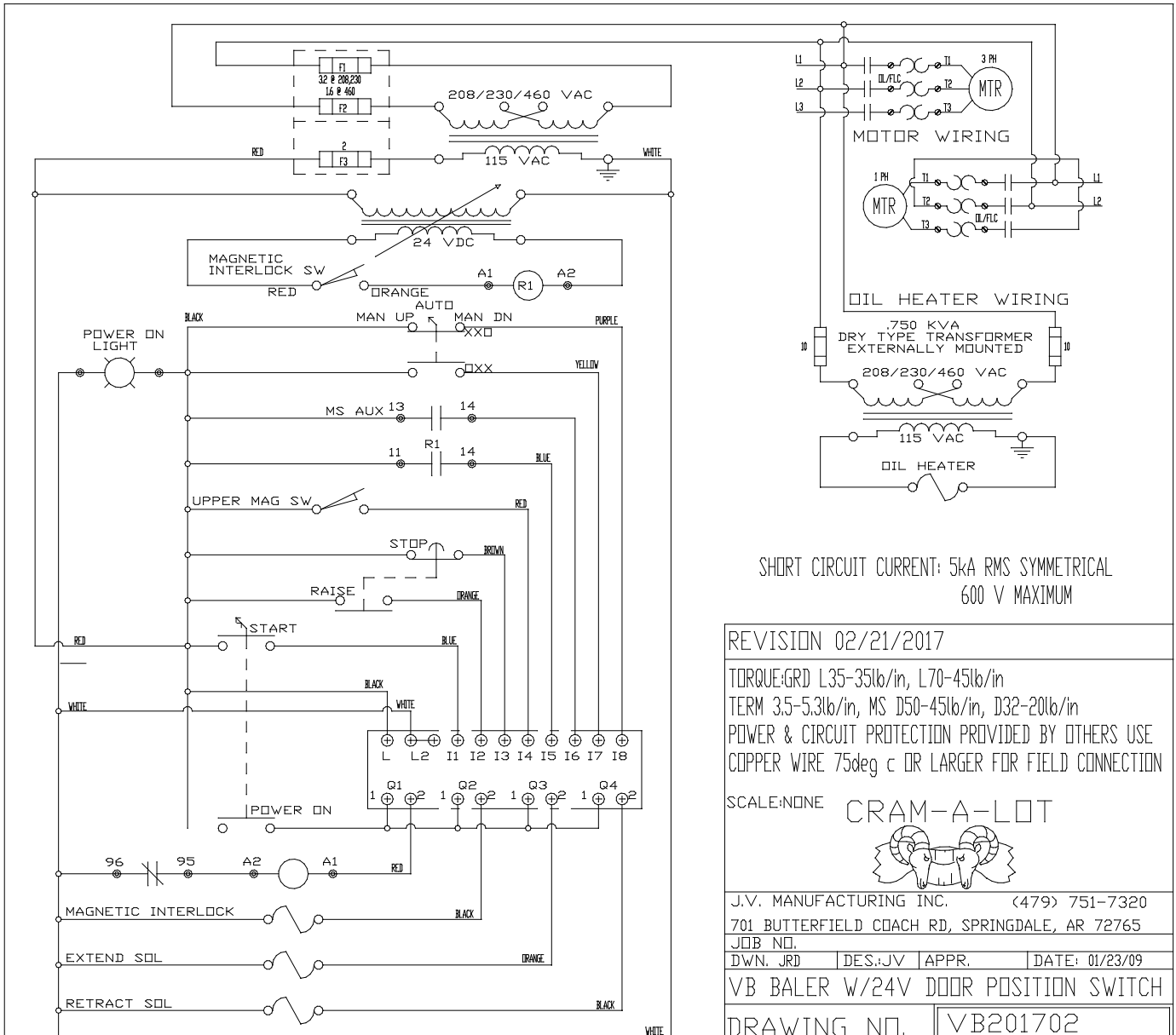

SHORT CIRCUIT CURRENT: 5ka RMS SYMMETRICAL  
600 V MAXIMUM

REVISION 02/21/2017  
 TORQUE:GRD L35-35lb/in, L70-45lb/in  
 TERM 3.5-5.3lb/in, MS D50-45lb/in, D32-20lb/in  
 POWER & CIRCUIT PROTECTION PROVIDED BY OTHERS USE  
 COPPER WIRE 75deg c OR LARGER FOR FIELD CONNECTION  
 SCALE:NONE **CRAM-A-LOT**

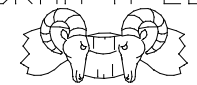

J.V. MANUFACTURING INC. (479) 751-7320  
 701 BUTTERFIELD COACH RD, SPRINGDALE, AR 72765  
 JOB NO.  
 DWN. JRD DES.:JV APPR. DATE: 01/23/09  
 VB BALER W/24V DOOR POSITION SWITCH  
 DRAWING NO. VB201702

MDL	PROGRAM: PICO CONTROLLER "PICOV B12"															VOLTAGE		
SN	PROGRAM: LOGO CONTROLLER "VB_LOGO_FBD"															60 hz		
DATE	5HP 3PH			5 HP 1 PH			10 HP 3PH			15 HP 3PH			20HP 3PH					
BUILT BY	208	240	480	230	240	208	240	480	575	208	240	480	575	208	240	480		
FULL LOAD CURRENT-AMPS	15	14	7	23	40	28	26	13	10.3	40	38	19	17	56	52	26		
MINIMUM CIRCUIT AMPACITY	19	17	8	28	50	35	32	16	13	50	47	24	21	70	65	32		
MAX OVCUR DEV TIME DELAY FUSE-AMPS	35	30	15	50	90	60	60	30	23	90	85	45	38	125	100	60		
MINIMUM WIRE SIZE (AWG)	10	12	14	10	8	8	8	12	10	6	6	10	10	4	4	8		

# Hydraulic Schematics

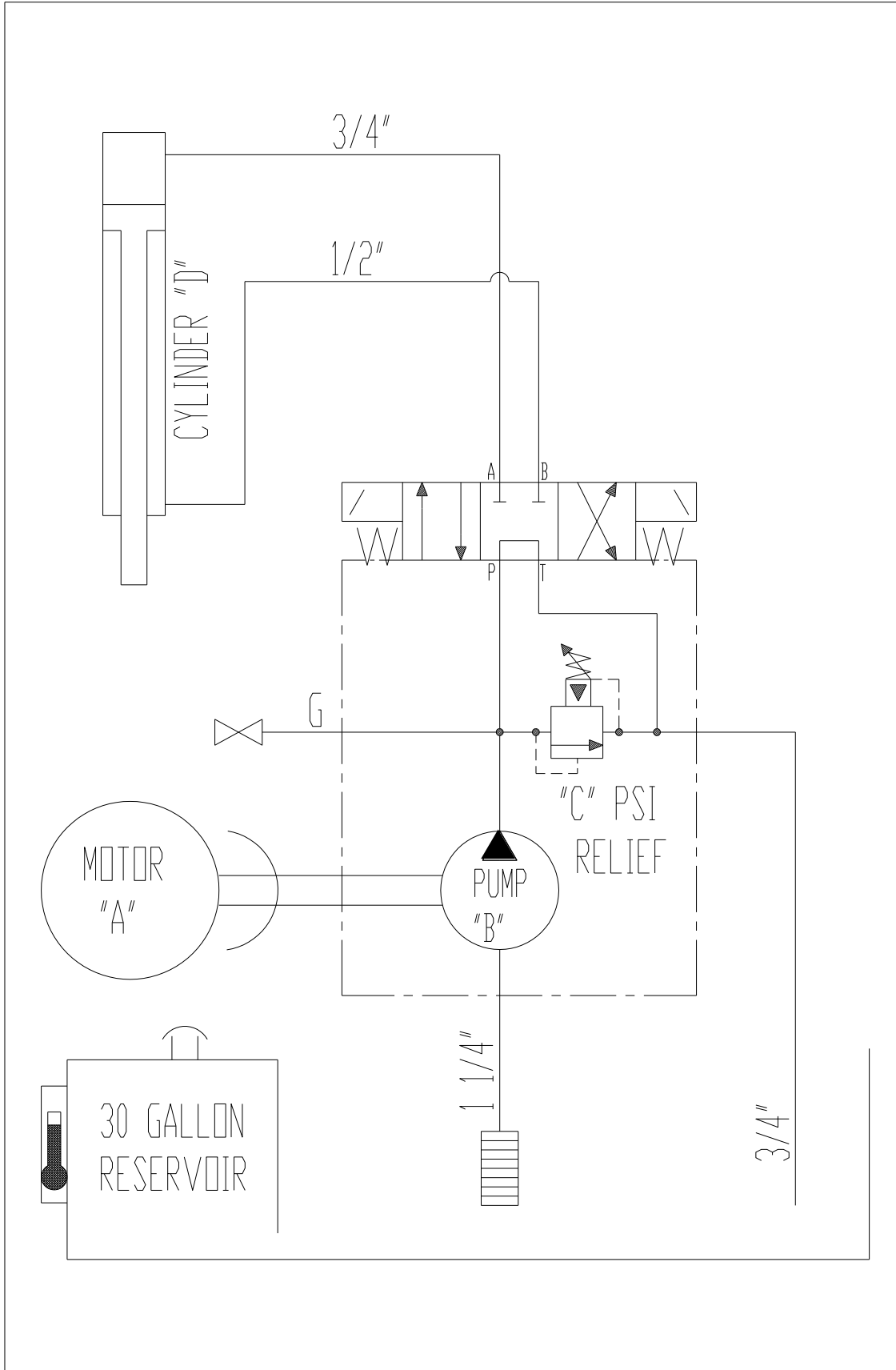

MODEL	"A" MOTOR	"B" PUMP	"C" RELIEF	"D" CYLINDER
VB-**-B	10 HP	9 GPM	2100 PSI	6 x 44 x 3.5
VB-**-T	15 HP	10.5 GPM	2400 PSI	6 x 52 x 4
VB-**-H	15 HP	10.5 GPM	2400 PSI	7 x 52 x 4
VB-**-X	20 HP	13.5 GPM	2400 PSI	7 x 52 x 4

CRAM-A-LOT

J.V. MANUFACTURING INC. (501) 751-7320  
701 HWY. 265S, P.O. BOX 229, SPRINGDALE, AR. 72765

JOB NO. \_\_\_\_\_ DES. \_\_\_\_\_ APPR. \_\_\_\_\_ DATE: 02/27/07

VB VERTICAL BALER

DRAWING NO. VB-HYD ALL MODELS

# Warranty Policy

## TERM

Unless terminated as hereinafter provide, this warranty shall continue in full force for a period of three years, and shall govern all transactions between the parties hereto following the completion of installation of the product at the end user's facility, and evidenced by a signed and dated installation report and warranty registration returned to J.V. Manufacturing, Inc. If no registration card is remitted or the installation is not provided by the factory, the warranty period shall be considered to start on the date of shipment.

As limited herein, the *CRAM-A-LOT*<sup>®</sup> products (the "goods") you have purchased are warranted by J.V. Manufacturing, Inc. ("seller") through the specified period to be free of defects in material and workmanship. This warranty does not apply to any damage caused by negligence, misuse, modifications, alterations, or accidents by purchaser or third parties.

Owning *CRAM-A-LOT*<sup>®</sup> quality is as easy as 1-2-3! J.V. Manufacturing, Inc will furnish without charge:

- 1) All parts and labor expenses through the first year of ownership to remedy any faults proven to be the result of defective materials or workmanship.
- 2) All parts through the second year of ownership to remedy any faults proven to be the result of defective materials or workmanship.
- 3) All labor expenses through the third year of ownership to remedy any structural faults proven to be the result of defective materials or workmanship.

## LIMITED WARRANTY

Seller's liability under warranty shall be limited to the repair and replacement of parts and the necessary labor and services required to repair the goods and shall be in lieu of any other remedy available under applicable law and shall not to exceed the purchase price of the goods. IT IS EXPRESSLY AGREED THAT THIS WARRANTY WILL BE IN LIEU OF ALL OTHER WARRANTIES WHETHER EXPRESS OR IMPLIED, OF FITNESS AND IN LIEU OF THE WARRANTY OF MERCHANTABILITY, AND ALL SUCH OTHER WARRANTIES ARE HEREBY REVOKED AND DISCLAIMED. **WARRANTY "VOID" UPON NON-PAYMENT.**

- Seller neither assumes nor authorizes any representative or person to assume for seller any other liability in connection with the sale or shipment of our products.
- Seller reserves the right to make changes or improvements in our products without notice and without incurring any obligation to prospective customers.
- Seller reserves the right to make changes or improvements in our products without incurring any obligation to similarly alter products previously purchased.
- Except in the case of damages or defect attributable to the Seller, Buyer shall not make any claim against Seller for any damaged or defective product or part.
- If Seller breaches or repudiates this contract, Buyer shall not be entitled to recover any incidental damages as that term is defined in the Uniform Commercial Code.
- If Seller breaches or repudiates this contract, Buyer shall not be entitled to any consequential damages as defined in the Uniform Commercial Code.
- Seller does not warrant that any product purchased shall conform to: (1). any affirmation of fact or promise relating to it, or (2). any description of it. No affirmation, promise, or description relating to any product purchased shall be deemed part of the basis of the parties bargain.
- No agent, employee, or representative of Seller has any authority to bind Seller to any affirmation, representation, or warranty concerning the goods sold under this contract, and unless an affirmation, representation, or warranty made by agent, employee, or representative is specifically included within this contract, it will not be enforceable by Buyer.

## ITEMS NOT COVERED

Seller waives the standard warranty on the following components and systems: Downstroke Baler bale ejection system - to include dump rods, dump handles, dump trays and associated components; Sonozaire hoses and fittings; Broken or lost machine keys; Broken or bent limit switch arms; All fuses and thermal / voltage / current limiting devices; Guide islands, wheel-stops, and anchor bolts; Container nose rollers.

## RETURN OF PRODUCTS OR SERVICE PARTS FOR REPAIR OR CREDIT

Unless Seller shall have authorized or permitted the return of any products or parts, in writing, or by phone with Return Material Authorization (RMA) Number assigned by J.V. Manufacturing, Inc. to the specified product or parts, seller shall not be obligated to accept from Buyer any products or parts returned, nor to make any exchange thereof, nor to credit Buyer therefor.

# ***Warranty Policy, continued***

---

## **NOTICE OF CLAIMS**

- A) Buyer must notify Seller immediately by e-mail, phone, writing, or fax, of any defect, malfunction, or nonconformity after he or she knows or has reason to know the basis of any claim, and in no event more than ten days thereafter. Within 24 hours after receiving notice from the buyer, Seller will authorize repair or replacement of the defective part. (1) J.V. Manufacturing, Inc., at its sole discretion, will have the option to make repairs or authorize a distributor or third party to make repairs. (2) All claims for repairs must be accompanied with a Warranty Job Order Number. Failure to obtain a Job Order Number will relieve Seller from all liability.
- B) Failure to give the notice prescribed by Subsection shall relieve the seller from all liability on any claim in respect to any transaction growing out of this warranty.
- C) The provisions of this shall survive the termination of any other portions of this warranty.

## **COMMON CARRIERS AGENTS OF DISTRIBUTOR**

Whenever Seller shall deliver or cause to be delivered to a common carrier any goods ordered by Buyer, whether the particular carrier shall have been designated in the shipping or routing instructions of the Buyer or not, Seller shall not be responsible for any delays or damages in shipment and the common carrier, to which Seller shall deliver goods shipped to the Buyer, is declared to be the agent of the Buyer.

## **COMPLETENESS OF INSTRUMENT**

This instrument contains all of the agreements, understandings, representations, conditions, warranties, and covenants made between parties hereto. Unless set forth herein, neither party shall be liable for any representations made, and all modifications and amendments hereto must be in writing.

## **COMPLETENESS OF INSTRUMENT**

This instrument contains all of the agreements, understandings, representations, conditions, warranties, and covenants made between parties hereto. Unless set forth herein, neither party shall be liable for any representations made, and all modifications and amendments hereto must be in writing.

## **NO IMPLIED WAIVERS**

The failure of either party at any time to require performance by the other party of any provision hereof shall not affect in any way the full right to require such performance at any time thereafter. Nor shall the waiver by either party of a breach of any provision hereof be taken or held to be a waiver of the provision itself.

## **CONTROLLING LAW**

The validity, interpretation, and performance of this warranty shall be controlled by and construed under the laws of the State of Arkansas, the state in which this warranty is being executed. It is understood, however, that this is a general form of warranty, designed for use in the United States wherever the Seller may desire to sell its products and that any provision herein which in any way contravenes the laws of any state or jurisdiction shall be deemed not to be a part of this warranty therein.

## **BUYER NOT AN AGENT**

This warranty does not constitute the Buyer as the agent or legal representative of the Company, or the Company as the agent or legal representative of the Buyer for any purpose whatsoever. Neither party is granted any express or implied right or authority by the other party to assume or create any obligation or responsibility on behalf of or in the name of the other party, or to bind the other party in any manner or thing whatsoever.

## **FINALITY OF THIS WRITING**

The parties intend this document to be the final expression of their agreement and it is intended also as a complete and exclusive statement of the terms of their agreement. No course of prior dealing between the parties and no usage of the trade shall be relevant to supplement or explain any term used in this document. Acceptance or acquiescence in a course of performance rendered under this document shall not be relevant to determine the meaning of this contract even when the accepting or acquiescing party has knowledge of the nature of the performance and opportunity for objection.

## **OPTIONAL EXTENDED WARRANTY**

Call for details.

# ***Warranty Procedures***

---

## **To request a warranty repair:**

1. All warranty repairs must be administered through **CRAM-A-LOT**<sup>®</sup> Customer Support. Failure to contact Customer Support before performing repairs may result in the denial of your warranty claim and may void the warranty on your machine.
2. Contact Customer Support by phone, fax, or e-mail, as soon as possible after identifying any defect, malfunction, or nonconformity.
3. Please provide the following information when contacting Customer Support for service: Customer name / Store number, Model Number, Serial Number, Shipping Address, Billing Address, and a description of the defect, malfunction, or nonconformity.
4. A Customer Support representative will open a service order and dispatch a Factory Authorized Service Technician to assess the repairs at the machine location within 24 hours.
5. The service technician will make repairs or order any necessary parts to correct the defect, malfunction, or nonconformity. Parts will be delivered to the Service Technician or to the customer's shipping address, at the discretion of the Customer Support representative.
6. The service technician will correct the defect, malfunction, or non-conformity to the customer's satisfaction. Any parts or components that have been diagnosed as defective will be returned to be evaluated by **CRAM-A-LOT**<sup>®</sup> Quality or Engineering Department personnel, or the vendor who supplied the part, as determined by **CRAM-A-LOT**<sup>®</sup> Customer Support
7. The warranty claim will be denied if any parts are found to be defective as the result of damage or neglect on the customer's part. In this case the customer will be notified and invoiced for the repair.

## **CRAM-A-LOT**<sup>®</sup> **CUSTOMER SUPPORT**

**Tel: 800-754-4290**

**Fax: 479-751-7870**

**Hours: 8:00a.m–5:00p.m. CST**

**Monday – Friday**

**service@jv.com**